

# GS412PA GS412PS

OPERATING INSTRUCTIONS - I



LANEY AMPLIFICATION  
[www.laney.co.uk](http://www.laney.co.uk)

 МУЗЦЕНТР  
МУЗЫКАЛЬНОЕ ОБОРУДОВАНИЕ  
<https://muzcentre.ru>

**GS412PA**  
**GS412PS**

# Laney

---

Dear Player,

Thank you very much for purchasing your new Laney product and becoming part of the worldwide Laney family. Each and every Laney unit is designed and built with the utmost attention to care and detail, so I trust yours will give you many years of enjoyment.

Laney products have a heritage which stretches back to 1967 when I first began building valve amplifiers in my parent's garage. Since then we have moved on from strength to strength developing an extensive range of guitar, bass, public address and keyboard amplification products along with a list of Laney endorsees that includes some of the world's most famous and respected musicians. At the same time we believe we have not lost sight of the reason Laney was founded in the first place - a dedication to building great sounding amplification for working musicians.

Warm Regards,



Lyndon Laney CEO



## INTRODUCTION

The GS412PA & GS412PS are a pair 4 x 12" cabinets developed for use with amplifiers such as GH50L, GH100L or VH100R from the Laney range - but equally would be a great addition to your existing guitar amplifier.

Rated at 240W Mono (or 2\*120W Stereo) these cabinets can be used in isolation, or together to form an 8 x 12 stack and feature top quality construction, Celestion Vintage 30 drivers with a larger robust plywood cabinet, switchable impedance, large side bar handles, castor cups on top of the straight cabinet to allow stacking, stainless steel corner protection and a set of roadworthy casters mounted to each model for ease of mobility.

Every Laney product is extensively play tested by experienced guitarists to ensure it has the tone and durability to perform at the very highest level, before being shipped to our customers.

We hope you enjoy using your new extension cabinet as much as we enjoyed designing and making it. It should give you years of trouble-free service, however please take time to read this manual, as it will allow you to get the best from your GS412PA or GS412PS.

Best wishes from all at Laney.

## UNPACKING INSTRUCTIONS

1. Open top of carton, remove top foam tray and open protective bag, pull back to sides.
2. Flip carton over. Cabinet rests on its castors.
3. Remove the Carton, bottom foam tray and protective bag.
4. Enjoy.

## CHECK CONTENTS ARE ALL INCLUDED

ITEM NO.	DESCRIPTION	QTY
1	Cabinet	1
2	Top Foam Tray	1
3	Bottom Foam Tray	1
4	Cardboard Inserts	2
5	User Manual	1

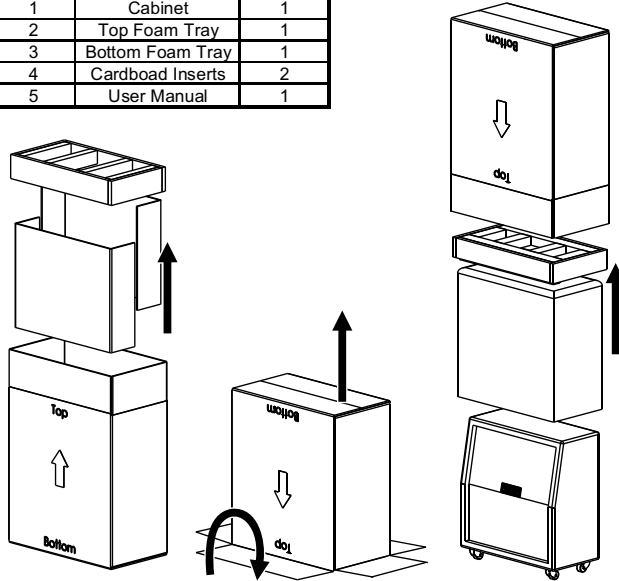

Always use good quality speaker cables

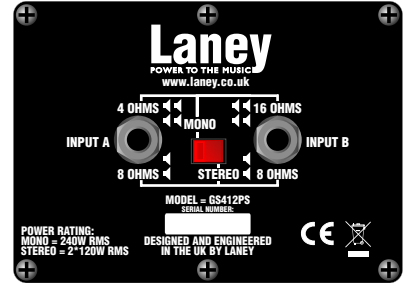

SPECIFICATIONS	GS412PA GS41PS
Impedance	Switchable Impedance
Loudspeaker	4 x 12" Celestion Vintage 30
Power Rating	Mono 240W RMS Stereo 2*120W RMS
Size W*D*H	758*358*758
Weight	42.5 Kg

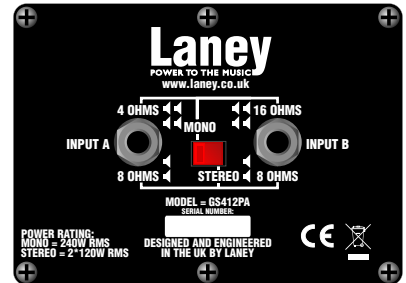

INPUT	IMPEDANCE	M/S SWITCH	OPERATES
A	4 Ohms	Mono	All Speakers
B	16 Ohms	Mono	All Speakers
A	8 Ohms	Stereo	RH Half of Cab
B	8 Ohms	Stereo	LH Half of Cab

# Laney



Connected to the single 16 ohm socket.

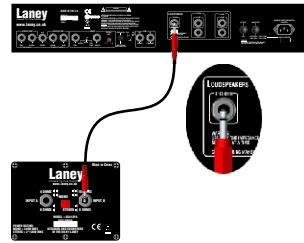

4 \* 12 system using  
1 \* VHI00R Head  
1 \* GS412PA

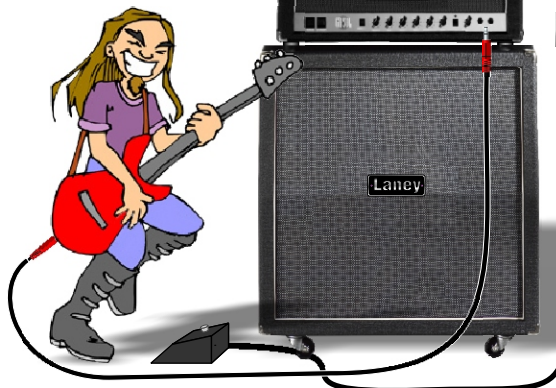

Stereo system using  
2 \* GH50L Heads  
1 \* GS412PA  
& FX Controller

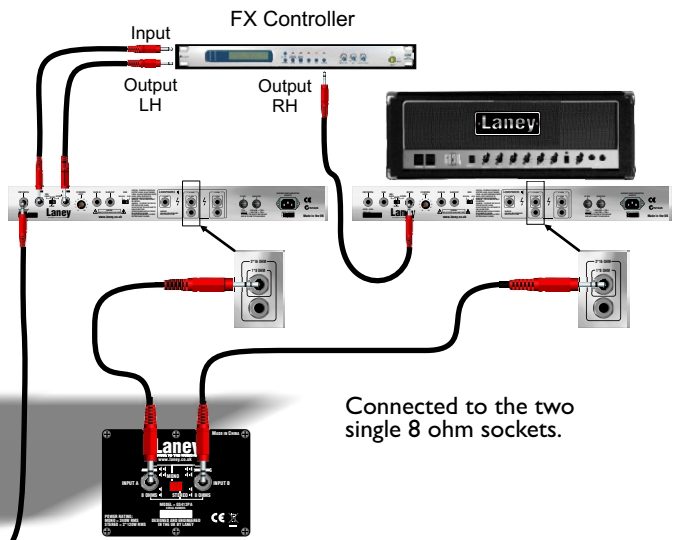

Connected to the two single 8 ohm sockets.

SAMPLE SYSTEMS

- 8 \*12 stack system using
- 1\* GH50L Head
- 1\* GS412PA
- 1\* GS412PS

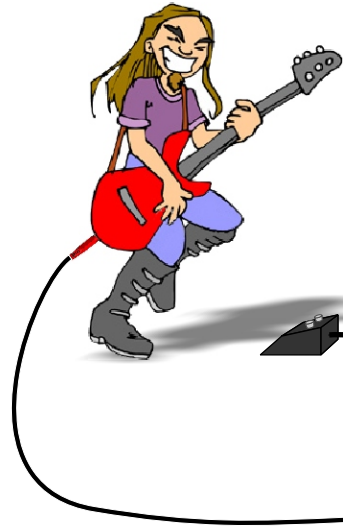

Connected to the two 16 Ohm sockets.

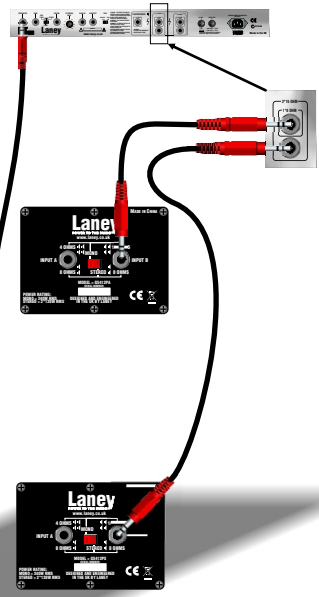

# Laney

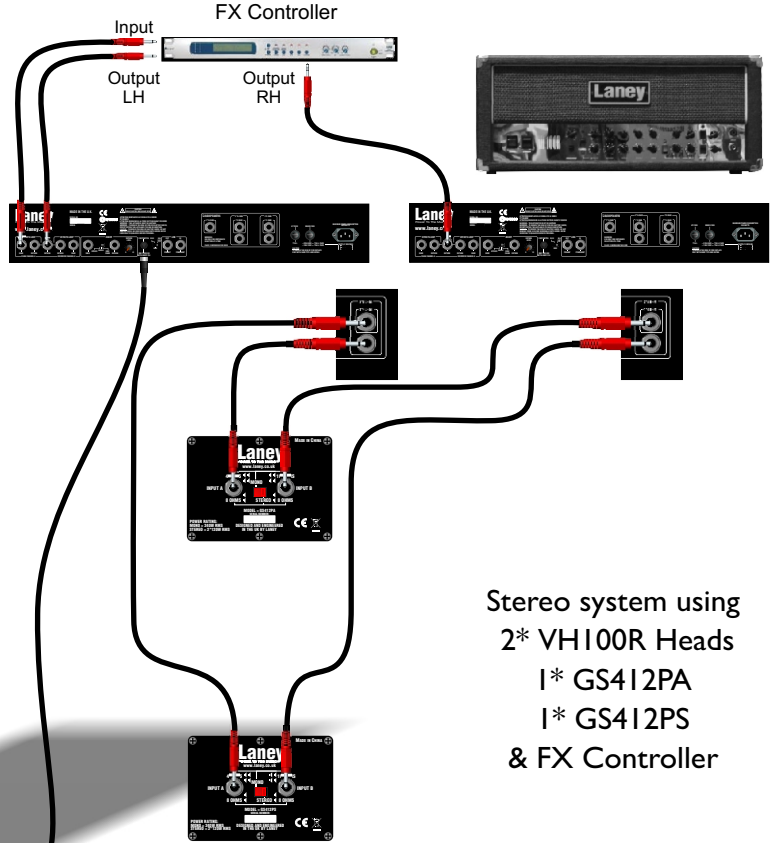

Stereo system using  
 2\* VH100R Heads  
 1\* GS412PA  
 1\* GS412PS  
 & FX Controller

## IMPORTANT SAFETY INSTRUCTIONS

- 1). **Read & Retain these Instructions** carefully before installing or operating this product.
- 2). **Comply with Warnings:** All warnings and instructions for these products should be adhered to.
- 3). **Unpacking:** On unpacking your product please check carefully for any signs of damage that may have occurred whilst in transit from the Laney factory to your dealer. In the unlikely event that there has been damage, please repack your unit in its original carton and consult your dealer. We strongly advise you to keep your original transit carton, since in the unlikely event that your unit should develop a fault, you will be able to return it to your dealer for rectification securely packed.
- 4). **Amplifier Connection:** In order to avoid damage, it is advisable to establish and follow a pattern for turning on and off your system. With all system parts connected, turn on source equipment, tape decks, cd players, mixers, effects processors etc, BEFORE turning on your guitar amplifier. Many products have large transient surges at turn on and off which can cause damage to your speakers.  
By turning on your guitar amplifier LAST and making sure its level control is set to a minimum, any transients from other equipment should not reach your loud speakers. Wait till all system parts have stabilised, usually a couple of seconds. Similarly when turning off your system always turn down the level controls on your guitar amplifier and then turn off its power before turning off other equipment
- 5). **Cables:** Never use shielded or microphone cable for any speaker connections as this will not be substantial enough to handle the amplifier load and could cause damage to your complete system.
- 6). **Caution:** These professional loudspeaker systems are capable of generating very high sound pressure levels. Use care with placement and operation to avoid excessive levels that can cause permanent hearing damage.
- 7). **Exposure** to extremely high noise levels may cause a permanent hearing loss. Individuals vary considerably in susceptibility to noise induced hearing loss, but nearly everyone will lose some hearing if exposed to sufficiently intense noise for a sufficient time. The U.S. Government's Occupational Safety and Health Administration (OSHA) has specified the permissible noise level exposure in the chart opposite.  
According to OSHA, any exposure in excess of the above permissible limits could result in some hearing loss. Ear plugs or protectors in the ear canals or over the ears must be worn when operating this amplification system in order to prevent a permanent hearing loss if exposure exceeds the limits set forth opposite. To ensure against potentially dangerous exposure to high sound pressure levels it is recommended that all persons exposed to equipment capable of producing high sound pressure levels such as this amplification system be protected by hearing protectors while this unit is in operation.
- 8). **Servicing:** The user should not attempt to service these products. Refer all servicing to qualified service personnel

Duration Per Day In Hours	Sound Level dBA, slow response
8	90
6	92
4	95
3	97
2	100
1 ½	102
1	105
½	110



In order to reduce environmental damage, at the end of its useful life, this product must not be disposed of along with normal household waste to landfill sites. It must be taken to an approved recycling centre according to the recommendations of the WEEE (Waste Electrical and Electronic Equipment) directive applicable in your country.

This product conforms to the requirements of the following European Regulations, Directives & Rules:-  
 CE Mark (93/68/EEC), Low Voltage (72/23/EEC), EMC (93/68/EEC),  
 RoHS (EU2002/95/EC), WEEE (EU2002/96/EC)

**Laney**  
POWER TO THE MUSIC

LANEY AMPLIFICATION  
[www.laney.co.uk](http://www.laney.co.uk)

In the interest of continued product development, Laney reserves the right to amend product specification without prior notification.